

Model: ENERGY
ET45

SPECIFICATIONS:
 Year of Intro 2000
 Thrust 45LBS
 Volts 12VDC
 Amp Draw 0 to 48 amps
 Mount 09 Transom
 Speeds 5/2

PARTS ORDERING & TECH ASSISTANCE
 MotorGuide Consumer Relations
 Phone 918-831-6989
 Fax 800-982-8093

Returned Goods must be accompanied with a Returned Goods Authorization. Contact MotorGuide Consumer Relations to obtain RGA.

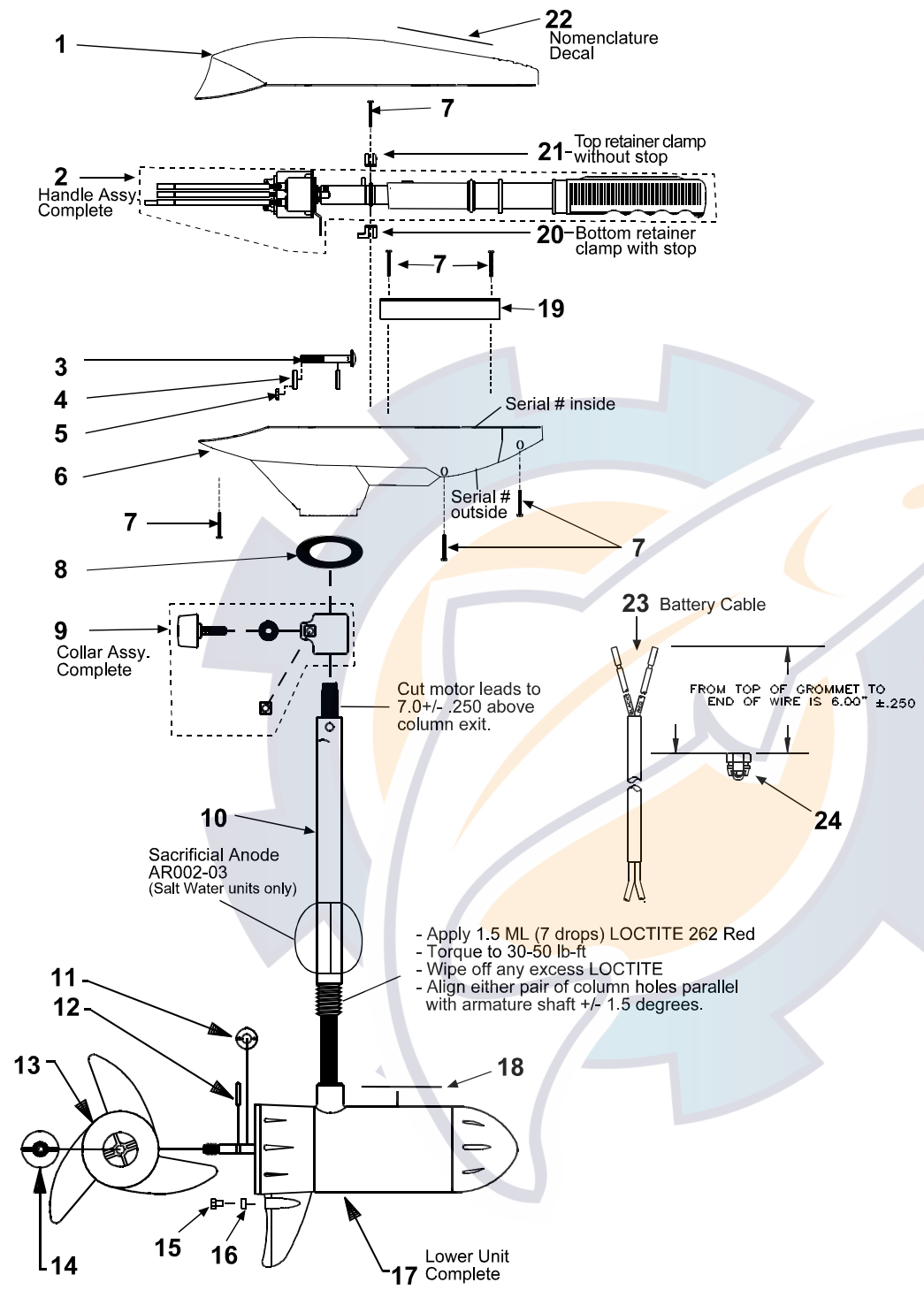

KEY	DESCRIPTION	PART #	KEY	DESCRIPTION	PART #	KEY	DESCRIPTION	PART #
1	TOP HOUSING COVER BLACK	ET053-17	10	COLUMN 36"	TT049-05	16	ANODE (Saltwater models only)	AR002-02
2	HANDLE ASY	BT372-09	11	COLUMN 42"	TT049-06	17	MOTOR	DM397-06
3	BOLT	TT134-02	12	COLUMN 50"	FR049-13	18	LOWER UNIT DECAL	ET060-08
4	CURVED WASHER	TT171-08	13	PROP DRIVE PIN	AR175-01	19	CABLE PLATE	AT155-06
5	NYLON LOCK NUT	XT098-02	14	MONOFILAMENT WASHER	BR102-01	20	BOTTOM RETAINER CLAMP	AR036-05
6	T/H BASE BLACK	ET004-16	15	PROP/2 BLADE	AF124-12	21	UPPER RETAINER CLAMP	AR036-04
7	#8 X 5/8 SCREW	AT141-01		PROP/3 BLADE	AF124-07	22	NOMENCLATURE DECAL	HT056-17
8	COLUMN SEAL	AT079-01		PROP NUT	AR099-01	23	BATTERY CABLE	XT328-06
9	DEPTH ADJUSTMENT COLLAR	AR158-01		ANODE BOLT (Saltwater models only)	DK133-01	24	GROMMET	GR019-01

LOWER UNIT BREAKDOWN

Model:
ET45

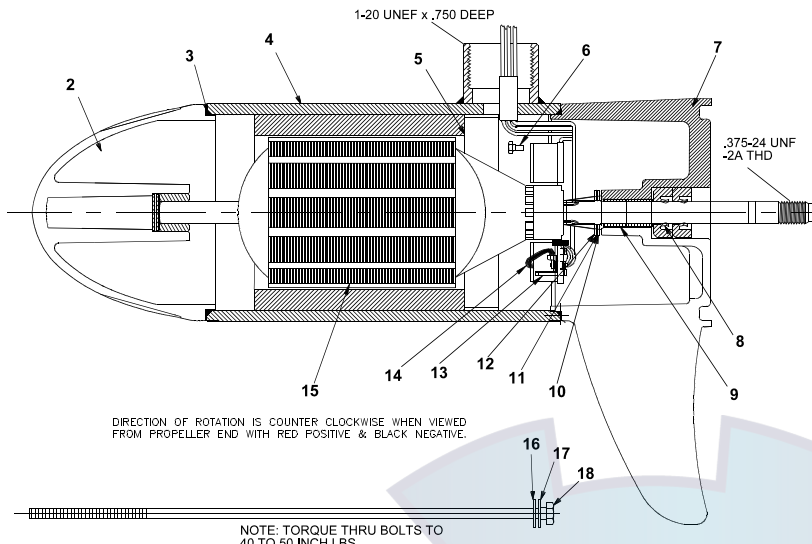

KEY	QTY	DESCRIPTION	PART NO.
1	X	MOTOR	DM397-06
2	1	NOSE CAP	XF3212-01
3	2	O RING SEAL	MR217-01
4	1	HOUSING ASY	JF3210-01
5	1	RETAINER	JF233-01
6	2	BRUSH CARD SCREW	MR228-01
7	1	COMM CAP	EF3205-04
8	2	SHAFT SEAL	MR223-01
9	1	BEARING	MR206-01
10	1	NYLATRON WASHER	MR226-01
11	1	WASHER	MR227-01
12	1	E RING	MR219-02
13	2	BRUSH SPRINGS	MR214-02
14	1	BRUSH ASY PLUG IN	JF3202-01
15	1	ARMATURE	CM3207-01
16	4	STATIC SEAL	MR222-01
17	4	THRU BOLT WASHER	MR216-02
18	2	THRU BOLT	MR218-03
19	1	BRUSH CARD	SM3201-03

WIRING

